



## ENGINEERED WOOD FLOORING

### Recommendations For Receiving, Installation, Finishing, and Maintenance

Thank you for purchasing a wood floor from Pioneer Millworks. Your floor was custom-made in our shop by skilled craftsmen, using the best reclaimed and sustainable woods available. As with any natural material, reclaimed wood has many variations which make your floor special — there isn't another one just like it in the world! As you un-bundle your flooring, you'll see the range of color, grain, texture, and character, which are outlined in the grade specifications for your particular order. At the end of the project, you'll see how they all come together to create your one-of-a-kind floor.

**Pioneer Millworks recommends that our flooring be installed and finished by an experienced wood flooring professional. The guidelines contained herein are provided for information only. Pioneer Millworks does not assume responsibility for the actual installation, or jobsite finishing quality of our flooring.**

### Acclimating Your Floor

The first step after the wood is unloaded is to acclimate the floor to the space where it will be installed. While engineered

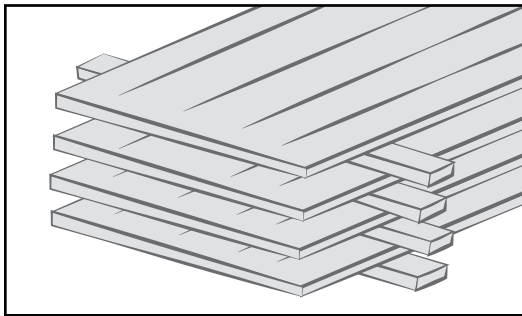

flooring doesn't need to be acclimated as long as a solid floor, it is still advisable to bring the flooring up to the approximate temperature and humidity to be expected in the space. Unbundle your flooring and stack each plank so that air is able to circulate through the stack. Thus, acclimating each piece to it's new environment.

**Use shorter lengths of flooring for cross-pieces, spaced about 24" apart, and longer lengths in the opposite direction. If you have a large volume of flooring, create several stacks in the same manner.**

### Installing Your Floor

Your flooring should be installed after all other "wet work," including drywall, tile work, and painting, is complete. If installing as a nail-down over plywood or other existing wood surfaces, we recommend first laying a layer of 15-pound roofing felt, or rosin paper, to reduce squeaks. If installing as a direct glue-down over concrete or other appropriate subfloor, follow the adhesive manufacturer's recommendations for testing and preparing the slab to ensure proper performance of the adhesive. Informational documents about various types of installation are published by the National Wood Flooring Association, and are available by visiting their web site.

[info@pionermillworks.com](mailto:info@pionermillworks.com) | [pionermillworks.com](http://pionermillworks.com) | t 585.924.9970 | f 585.924.9962



If you've purchased a random width floor from us, keep in mind that **there is no repeating pattern implied or guaranteed**. Do not install the flooring in such a pattern (3,4,5,3,4,5, etc.) or you will run out of at least one of the appropriate widths before the installation is complete. Consult your packing list, which shows the quantity of each width supplied, and base the frequency of each width on the quantity shipped. This may necessitate laying out some of the final courses to ensure you have enough of the appropriate width to complete each run across a room.

## Sanding Your Floor

We mill our floors with very precise tolerances to minimize on-site sanding and surface prep work. However, the floor will likely get a few scuffs and scrapes during installation. For our un-finished floors, we recommend a light sanding to remove those marks, and to give the finish better adhesion. While installation and finishing by a professional contractor is highly recommended, the process of sanding and finishing a reclaimed floor is much like finishing any other hardwood floor, with a few exceptions:

**Settlers' Plank and other highly-textured unfinished floors** are best finished by first lightly screening the floor with an 80 to 100 grit screening pad on a floor buffer, or random orbital sander. This will remove burrs, pillow some of the over-wood (a small block plane or utility knife is also helpful), and smooth rougher spots in the texture of the floor without cutting too far into the floor. **Never use a drum sander on these floors** — *this will remove the rich patina and variations in texture that make the floor so special!* After screening, check for any rough areas and smooth them out with a palm sander fitted with the same grit of paper used above. Then, vacuum the floor clean, and finish the floor according to the recommendations of the finish manufacturer.

**All other species** should be sanded lightly with a fine grit screening pad on a floor buffer or random orbital sander, just enough to remove any mill marks and open the grade to better accept the finish. A drum sander typically is not necessary, and will only thin the wear layer of your floor. After sanding, vacuum the floor clean, and then finish the floor according to the recommendations of the finish manufacturer.

## Finishing Your Floor

Finishing your custom wood floor is an individual decision that by now you probably explored. Here are some options and recommendations for quality finishes:

**Hardwax Oil** — We like *Rubio Monocoat*. It's about as natural as you can get with an oil based finish and it has ZERO VOC's. It is available in a variety of tones from pure to black. Rubio Monocoat is easy to repair – just lightly sand the scratch or blemish and reapply a small amount of oil. Be sure to remove any excess oil after a few minutes and buff with a clean cloth.



**Water-based Polyurethane** — *PolyWhey* made by Vermont Natural Coatings is a super-durable clear coating that dries quickly without significantly altering the color of the wood. Designed for commercial use, this finish does just as well in residential applications. A floor finished with *PolyWhey* is easy to clean with off-the-shelf products, low in VOC's, and can often be easily spot repaired.

**Pre-finished** — If you have a pre-finished floor from Pioneer Millworks, then the work has already been done!

## Maintaining Your Floor

The single most important thing you can do to maintain the beauty of your floor is to keep dirt from getting on the floor in the first place. Think of dirt on your floor the same way you would sandpaper; the more you work it into the floor, the more damage it will do to the finish and the wood. Walk-off mats (with non-abrasive undersides) at outside entrances, frequent sweeping, and removing of shoes in the space will help keep dirt and grit out. Each individual finish manufacturer has specific recommendations for cleaning products that will extend the life of the finish. If you've purchased a pre-finished wood floor from us, consult your sales representative for information specific to your project.

Please keep in mind that your wood floor is a natural material, and seasonal movement in your flooring is to be expected. Planks that fit very tight in the summer may develop minor gaps in the drier winter months or when heating systems are in operation. In addition, the color of your floor will likely become deeper over time, and is part of the natural aging and oxidation of any wood. Because of this, you may notice that rugs which are left in place for a long period of time will slow the aging process, and once moved, reveal a lighter area where they once covered. Don't worry. Once exposed it too will age to match.

## Enjoying Your Floor

Before you throw away that scrap pile and sawdust, think green — **complete the circle!**

- Save at least one piece of each size for reference, just in case you ever need to order more
- Use the sawdust for composting or for mulch
- Use cut-offs (and the wood from your pallet) for fireplace kindling or for campfires
- Recycle the lumber wrap — it makes great weed matting in the garden

We want to hear from you! If you have any further questions, please feel free to contact us anytime at (800) 951-9663, or [myfloorsrock@pioneermillworks.com](mailto:myfloorsrock@pioneermillworks.com). We'd love to see photos of your finished project too — please e-mail them, and we'll send you a nice, soft, organic cotton Pioneer Millworks T-shirt along with a certificate of authenticity, suitable for framing, that describes the building and location that your wood came from! Additional information about wood flooring is available at [www.woodfloors.org](http://www.woodfloors.org), the website of the National Wood Flooring Association.

Thanks again for working with us to create **your** floor!

**Your Pioneer Millworks Team**

[info@pioneermillworks.com](mailto:info@pioneermillworks.com) | [pioneermillworks.com](http://pioneermillworks.com) | t 585.924.9970 | f 585.924.9962