

# Skyline™

MULTIDIMENSIONAL CLADDING

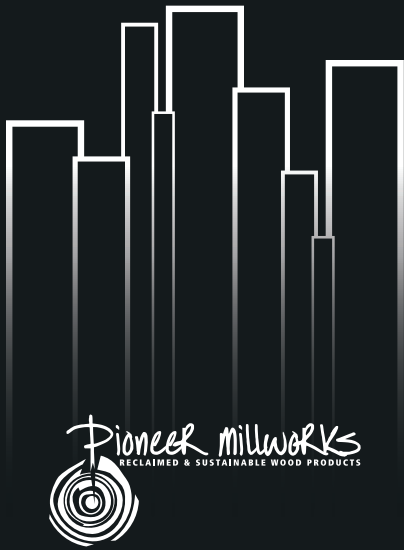

## Interior Applications

Skyline™ is a large-scale commercial wall cladding product line from Pioneer Millworks that is completely customizable—offering designers, architects, and builders the ability to create unique dynamic accent walls by combining a mix of our different colors, lengths, widths, and milling heights, giving any space a singular look and feel.

Skyline™ offers a unique opportunity to design sophisticated dimensional landscapes with our proprietary color palette that evokes diverse cityscapes from around the world.

- Inspired by dynamic urban landscapes
- Customizable in large scale
- Multidimensional applications
- All Natural no-VOC finish

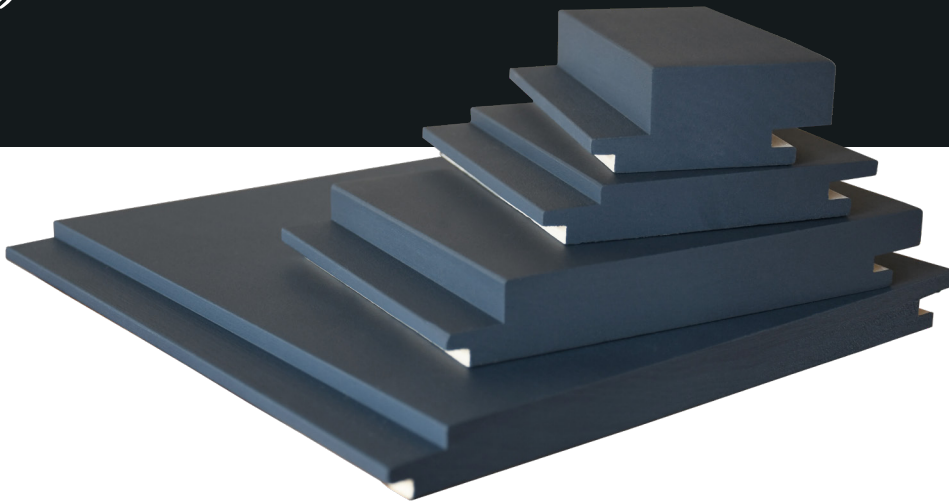

Oslo

Matera

Berlin

Sapporo

Gotham

Auckland

Ketchikan

Zanzibar

Sao Paulo

### Size

Skyline™ comes in a variety of different widths and milling heights that are universally interchangeable.

### Widths

7 1/4"  
5 1/4"  
3 1/4"  
2"

### Heights

1 1/8"  
7/8"  
5/8"

### Wood

Available in sustainably harvested hardwood.

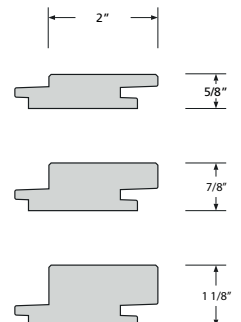
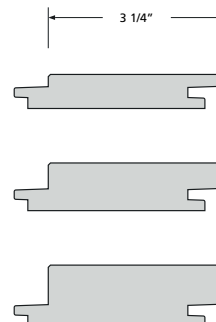
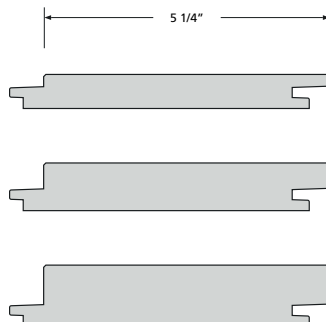
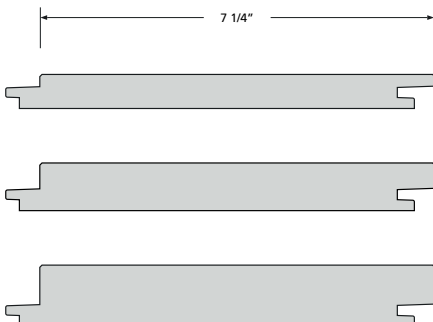

# Skyline™

MULTIDIMENSIONAL CLADDING

## CUT AND PASTE SPECIFICATION INTO APPROPRIATE CSI DIVISION

06 42 00—Wood Paneling

## MANUFACTURER

Pioneer Millworks East  
1180 Commercial Drive  
Farmington, NY 14425  
Phone: 800-951-9663

Pioneer Millworks West  
2655 NE Orchard Ave.  
McMinnville, OR 97128  
Phone: 503-437-9017

## MATERIALS

**Product Name:** Skyline™—Multidimensional Cladding

**Species/Description:** Paint Grade Hardwood

**Source:** Sustainably Harvested Forests

**Color:** Available prefinished in standard colors

**Grade:** Select

**Dimensions:**

**Solid**

TH—5/8", 7/8", 1-1/8"

WD—2", 3-1/4", 5-1/4", 7-1/4"

LG—Random, Interior- 6'-12'

**Milling:** Custom Skyline Profiles

**Finish:** Interior - solid color, matte, low VOC poly 2 coats on face.

**FSC Claim:** FSC Mix

## ADDITIONAL INFORMATION

**Heartwood:** No restriction

**Grain:** No restriction

**Knots:** Infrequent pin knots up to 3/8" in diameter may be present

**Texture:** Interior - Sanded Smooth

**Voids:** None allowed.

**Checks:** Minimal surface checking may be present.

**Moisture Content:** Interior: 6-9%

## LEED INFORMATION

**MRC1:** Building Life-cycle Impact Reduction.

**MRC2:** EPD Certification Available.

**MRC3:** FSC Mix

## RECOMMENDED COVERAGE

10–15% additional material for on-site trimming and installation factors.

\*Complex patterns, designs and color combinations may require more material than standard coverage

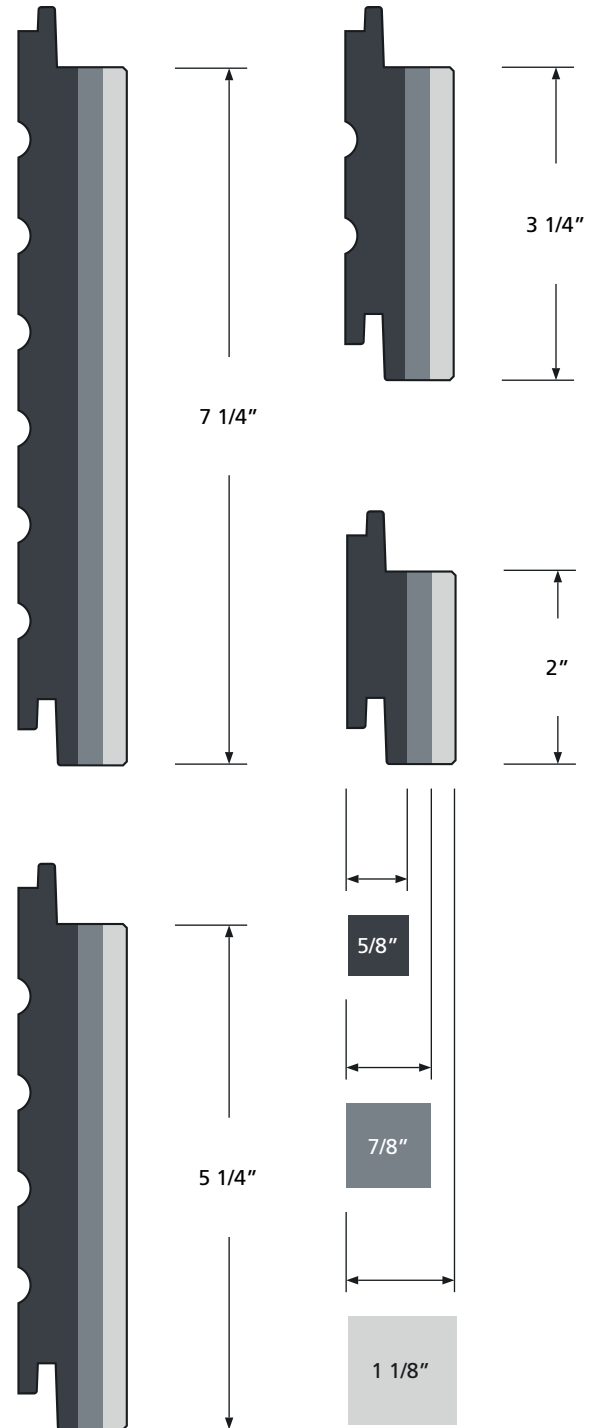

Information is deemed reliable but subject to change.  
All photos for representation only. Additional information available at our website or call our wood design experts.