



Sunset Collection

Reclaimed oak is the sturdy foundation of our Sunset Collection. Sourced from the iconic four rail fences that reign in fertile Kentucky pasturelands; these rescued planks corralled stoic thoroughbreds for decades. Our proprietary milling techniques preserve the oak's historic character, illustrating the detail in the grains and fissures from its previous life. Engineered for both stability and ease of installation, our Sunset Collection employs an all-natural plant-based UV Cured Hard-Wax Oil finish that is easy to maintain, durable, and safe for people, animals and the planet.

CUT AND PASTE SPECIFICATION INTO APPROPRIATE CSI DIVISION

09 64 20 — Reclaimed Wood Flooring
09 64 30 — Engineered Wood Flooring
06 42 00 — Wood Paneling

MANUFACTURER

Pioneer Millworks
1180 Commercial Dr
Farmington, NY 14425

MATERIALS

Product: Sunset Collection Reclaimed Oak

Collection: Sunset Collection

Species: Reclaimed Oak

Core: 9-Ply FSC® Certified & TCSA Compliant Birch Plywood

Texture: Smooth Planed

Source: Agricultural Deconstruction

Color: Tones may range from tan to brown and neutral tones.
Unlimited color variation is inherent to the product.

Finish: Naked, Pure, Canyon, Roan, Sabino, Nubuck, Dark Bay * *Shown in Canyon*

Hardness: **1290 - 1360**
(Janka Ball Test ASTM D143, Natural wood products have no minimum hardness since hardness is a characteristic of species and cannot be controlled)

DIMENSIONS & MILLING

Profile + End Match: **TGMBVE** (Tongue and Groove Micro-Bevel Edge)

Thickness: **5/8"**

Width: **4 1/2"** face

Length: **12"– 6.5'** random
(At least 20% of each order will be the longest length in the range)
Called lengths available

ADDITIONAL INFORMATION

Heartwood: No Restriction

Grain: No Restriction

Knots: No limitations on sound knots.
Surface defects from chipped or open knots may be present.

Texture: Surface should generally be 95% clear of saw marks or patina.

Voids: Voids up to 1" in diameter will be filled with a black composite.

Discoloration: Ferrous staining from previous fasteners may be present.

Checks: Structural checks not affecting the integrity of the plank, once installed, are allowed and more prevalent as the width of the material increases.

Moisture Content: Kiln dried 6–9% prior to milling.

CERTIFICATIONS & LEED INFORMATION

FSC® Claim: FSC Mix Credit (GFA-COC-008489)

GREENGUARD Gold Certified

MRc3: Low-Emmiting Materials (Greenguard Gold)

MRc4: Building Product Selection and Procurement
(FSC Mix Credit)

INSTALLATION RECOMMENDATIONS

Overage: **Minimum 10%** additional material
For on-site grading, trimming and installation factors.

Climate: As with any wood flooring product, the room temperature should be held at a consistent range between **60-80° F** with relative humidity between **30-60%**.
Environmental conditions consistently outside of these parameters could result in product performance issues.

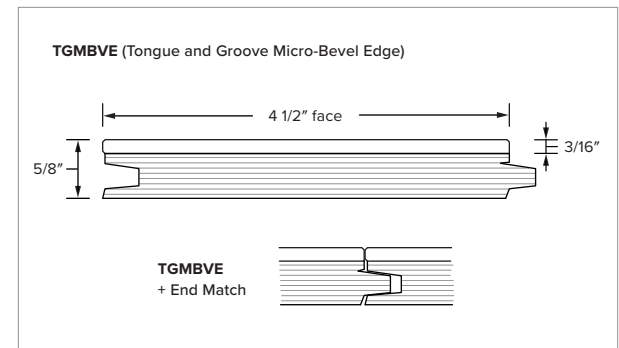



Naked

SKU# 29121810111



Pure

SKU# 29121810211



Canyon

SKU# 29122117911



Roan

SKU# 29122118011



Sabino

SKU# 29121817811



Nubuck

SKU# 29121817711



Dark Bay

SKU# 29121817611